



DOLINŠEK-S, d.o.o. Šempeter

Trgovina za prodajo navojnega, stružnega, rezalnega, vrtilnega orodja

Set zajema:
4 x ploščice in
cilindrično držalo

SPOT DRILL

Set za posnemanje robov, centriranje,
graviranje in V - utorjanje

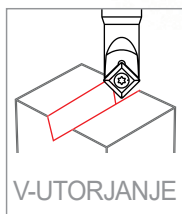
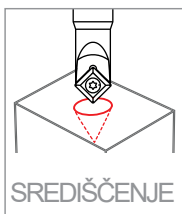

POSEBNA PROMOCIJA
Velja do razpodaje zalog

Cena seta 89,00€ + ddv

SPOT11	SPOTdrill Večopravilni sistem				ISO513	COATED			UNCOATED										
	Size	IC	S	D1		HCSOP	HCSOM	HCSOK	HMSON										
					P	100 220													
	11	11	3.97	2.2	M		60 140												
					K			80 180											
					N				150 300										
					S														
					H														
OBMOČJE UPORABE	Toga obdelava, stabilna obdelava																		
d primarna uporaba	Spremenljivi pogoji, splošna obdel.																		
d možna uporaba	Groba obdelava, nestabilni pogoji																		
SPLOŠNO	GP P M K	SPOT	11R03-GP	RE 0.3	f_n 0.04 0.07 0.10 f_r 0.08 0.15 0.22	h	h	h											
			11R08-GP	RE 0.8	f_n 0.04 0.07 0.10 f_r 0.08 0.15 0.22	h	h	h											
ALUMINI	AL N		11R04-AL	RE 0.4	f_n 0.06 0.09 0.12 f_r 0.14 0.22 0.30				h										
	polirana površina		11R08-AL	RE 0.8	f_n 0.06 0.09 0.12 f_r 0.14 0.22 0.30				h										

h stock standard hitrost pomikazaposnemanje

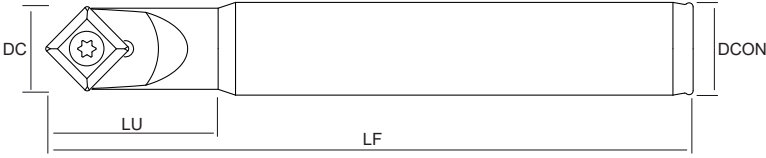
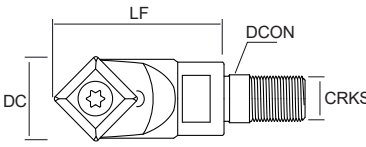
CILINDRIČNO											
Z NAVOJEM											
SPOTDRILL Večopravilni sistem		DC (DCX)	Z	DCON	LF	LU	CRKS	WT (Kg)	MIID		
Z NAVOJEM	NT-SPOT	D14-M08-L052	h	15.4 (14)	1	8.5	35	-	M8	0,03	SPOT11
	NT-SPOT	D14-S16-L100	h	15.4 (14)	1	16	100	30	-	0,13	SPOT11
CILINDRIČNO	NT-SPOT	D14-S16-L100	h	15.4 (14)	1	16	100	30	-	0,13	SPOT11
	NT-SPOT	D14-M08-L052	h	15.4 (14)	1	8.5	35	-	M8	0,03	SPOT11

h stock standard DCX=MAXIMALNI PREMIERREZANJA

VELIKOST PLOŠČICE	VIJAK		KLJUČ	
	11	NT-ST063 torque 3.5 Nm	NT-FTB15	



SET-SPOTDRILL
 1x NT-SPOTD14-S16-L100
 2x SPOT11R08-GP HC-ISO **P**
 2x SPOT11R08-GP HC-ISO **M**

€ 89,00

Dolinšek -S d.o.o.
 Vrtna ulica9
 3311 Šempeter
 03 703 30 13/ 14
 as@dolinsek-s.si
 ns@dolinsek-s.si